











SECTION 1

COPPER CONDUCTOR TERMINATIONS

This range of Utilux Copper Lugs and Links is generally designed for standard metric building cable conforming to AS1125-174. However other types of cable can be used with the correct crimping procedures. The range covers a variety of products including links with solid barriers for oil filled conductor and Sealed Copper Lugs for paper insulated conductors.

With over 80 years of experience Utilux has engineered the correct combination of material thickness and crimp die selection to ensure that the optimum compression ratios are achieved when crimping. Annealing also ensures that connectors can be crimped without damage and electro tinning minimises corrosion. These features combined with correct termination procedures will ensure a connection that will perform for many years. Please refer to your local Utilux Technical Sales Engineer for crimping recommendations or for further information.

CRIMP LUGS	STYLE	CONDUCTOR AREA	PAGE
	Copper Crimp Lug	2.5-1000	2
	Narrow Palm	35-300	4
	Copper Flared Lug	25-185	5
	Cable Lug Solder Type	10-240	10
	Sealed Copper Crimp Lug	25-630	10
	Bolted Cable Lug	4-500	12
	Cast Lugs	Custom	11
	Solid Palm Copper Lugs	6-35	14
	Long Palm Long Barrel Copper Crimp Lugs	25-630	11
STALK LUGS	STYLE	CONDUCTOR AREA	PAGE
	Copper Stalk Lug Type 1	35-185mm ²	9
	Copper Stalk Lug Type 2	16-95mm ²	9
CRIMP LINKS	STYLE	CONDUCTOR AREA	PAGE
	Copper Crimp Link	0.5-1000mm ²	6
	Copper Crimp Link Solid Barrier	10-630mm ²	7
	Reducing Link	16-300mm ²	8
CONNECTORS	STYLE	CONDUCTOR AREA	PAGE
	Crimp Cable Connector	1-2x50/0.25mm ²	7
C CONNECTORS	STYLE	CONDUCTOR AREA	PAGE
	C Connector	6-630mm ²	13
T-CLAMPS	STYLE	MAIN CABLE RANGE	PAGE
	Bolted Tee Clamp	70-240mm ²	12



COPPER CRIMP LUG

- Suitable for copper conductor • Range 0.5-1000 mm²
- Seamless copper tube • Electro tinned
- Cable area clearly identified on the lug
- Tested to AS/NZS 4325.1:1995

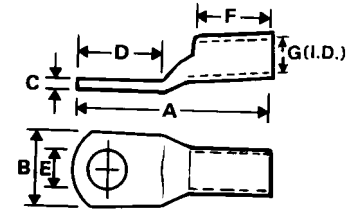

DESCRIPT.	CAT NO.	CONDUCTOR AREA (mm ²)	CONDUCTOR STRANDING	STUD SIZE	DIMENSIONS (mm ²)						NO. OF CRIMPS (Tool No.)							CRIMPING DIE
					A	B	C	D	F	G	76	00	18	20	21	22	38A	
CG0.5M4	H1399	0.5	1/0.80	M4	17.5	6.4	1.4	9.5	6.0	2.1	-	-	-	-	-	-	-	
CG0.5M4	H1400			M4	19.1	6.4	1.4	11.1	6.0	2.1	1	1	1	-	-	-	-	-
CG0.5SM5	H1401S			M5	19.1	8.7	1.0	11.1	6.0	2.1	1	1	1	-	-	-	-	-
CG0.5LM5	H1401L			M5	26.6	8.7	1.0	15.1	9.5	2.1	2	2	1	-	-	-	-	-
CG0.5M6	H1402			M6	26.2	10.3	0.9	15.1	9.5	2.1	2	2	1	-	-	-	-	-
CG0.5M8	H1402A			M8	26.2	11.1	0.8	15.1	9.5	2.1	2	2	1	-	-	-	-	-
CG2.5M4	H1436A	2.5	7/0.67	M4	21.4	9.1	1.1	11.9	8.0	2.5	2	1	1	-	-	-	-	
CG2.5M5	H1436			M5	21.4	9.1	1.1	11.9	8.0	2.5	2	1	1	-	-	-	-	-
CG2.5M6	H1437			M6	26.2	10.3	0.9	15.1	8.7	2.5	2	2	1	-	-	-	-	-
CG2.5M8	H1437A			M8	26.2	10.3	0.9	15.1	8.7	2.5	2	2	1	-	-	-	-	-
CG4SM5	H1403S	4	7/0.85	M5	21.0	8.7	1.5	11.1	8.0	3.3	2	1	1	-	-	-	-	
CG4LM5	H1403L			M5	27.3	8.7	1.5	14.7	9.2	3.3	2	2	1	-	-	-	-	-
CG4M6	H1404			M6	27.8	10.3	1.2	15.1	9.5	3.3	2	2	1	-	-	-	-	-
CG4M8	H1404A			M8	28.6	13.0	1.0	13.3	9.5	3.3	2	2	1	-	-	-	-	-
CG4M10	H1404B			M10	28.6	13.0	1.0	16.3	9.5	3.3	2	2	1	-	-	-	-	-
CG6M6	H1405	6	7/1.04	M6	27.0	10.3	1.2	15.0	9.5	3.7	-	2	1	-	1	1	1	
CG6M8	H1405A			M8	28.6	13.9	0.9	16.7	9.5	3.7	-	2	1	-	1	1	1	38-44CU
CG6M10	H1405B			M10	28.6	13.9	0.9	16.7	9.5	3.7	-	2	1	-	1	1	1	
CG10SM6	H1406S	10	7/1.35	M6	27.0	11.9	1.8	15.5	9.5	4.7	-	2	1	-	1	1	1	
CG10LM6	H1406L			M6	29.4	11.9	1.8	15.5	11.5	4.7	-	2	2	-	1	1	1	
CG10M8	H1406A			M8	28.6	14.3	1.6	16.3	9.5	4.7	-	2	1	-	1	1	1	38-57CU
CG10M10	H1406B			M10	30.6	14.3	1.6	16.3	9.5	4.7	-	2	1	-	1	1	1	
CG10M12	H1406C			M12	33.0	17.0	1.4	20.0	11.0	4.7	-	2	1	-	1	1	1	
CG16M5	H1407A	16	7/1.70	M5	39.7	11.6	2.3	16.3	20.6	5.5	-	-	3	2	2	2	1	
CG16M6	H1407			M6	39.7	11.6	2.3	16.3	20.6	5.5	-	-	3	2	2	2	1	
CG16M8	H1408			M8	39.7	13.5	1.9	16.3	20.6	5.5	-	-	3	2	2	2	1	38-63CU
CG16M10	H1408A			M10	41.5	13.5	1.9	18.5	20.6	5.5	-	-	3	2	2	2	1	
CG16M11	H1445			M11	43.6	16.7	2.8	19.0	22.2	5.5	-	-	-	2	2	2	1	38-77CU
CG16M12	H1408B			M12	46.0	17.5	1.4	20.5	19.0	5.5	-	-	-	2	2	2	1	38-63CU
CG20M6	H1409	20	19/0.44	M6	34.9	12.5	2.3	14.3	19.0	6.3	-	-	-	2	2	2	1	
CG20M8	H1410			M8	42.1	13.5	2.2	19.0	20.3	6.3	-	-	-	2	2	2	1	
CG20M10	H1411			M10	42.1	14.3	2.0	19.0	20.3	6.3	-	-	-	2	2	2	1	38-70CU
CG20M12	H1411A			M11	42.1	15.2	1.9	19.0	20.3	6.3	-	-	-	2	2	2	1	
CG25M6	H1415A	25	19/1.35	M6	43.6	16.7	2.2	19.0	22.0	7.1	-	-	-	2	2	2	1	
CG25M8	H1415			M8	43.6	16.7	2.2	19.0	22.0	7.1	-	-	-	2	2	2	1	
CG25M10	H1416			M10	43.6	16.7	1.9	19.0	22.0	7.1	-	-	-	2	2	2	1	38-77CU
CG25M11	H1416A			M11	43.6	16.7	1.9	19.0	22.0	7.1	-	-	-	2	2	2	1	
CG25M12	H1416B			M12	51.0	18.2	1.7	25.4	21.0	7.1	-	-	-	2	2	2	1	

DESCRIPT.	CAT NO.	CONDUCTOR AREA (mm ²)	CONDUCTOR STRANDING	STUD SIZE	DIMENSIONS (mm ²)						NO. OF CRIMPS (Tool No.)					CRIMPING DIE
					A	B	C	D	F	G	20	21	22	38A	40B	
CG35M6	H1365	35	19/1.53	M6	43.6	18.2	2.7	19.0	22.2	8.4	2	2	2	1	-	38-92CU
CG35M8	H1366			M8	43.6	18.2	2.7	19.0	22.2	8.4	2	2	2	1	-	
CG35M10	H1368			M10	43.6	18.2	2.7	19.0	22.2	8.4	2	2	2	1	-	
CG35M12	H1369			M12	51.2	20.0	2.4	24.5	22.0	8.4	2	2	2	1	-	
CG35M11	H1442	38	7/0.104	M11	51.6	19.0	3.7	27.0	22.2	8.7	2	2	2	1	-	38-104CU
CG50M8	H1419	50	19/1.78	M8	51.6	18.2	3.1	27.0	22.2	9.5	2	2	2	1	-	38-104CU
CG50M10	H1420			M10	51.6	19.0	3.0	27.0	22.2	9.5	2	2	2	1	-	
CG50M12	H1421			M12	51.6	20.6	2.8	27.0	22.2	9.5	2	2	2	1	-	
CG70M6	H1422B	70	19/2.14	M6	54.0	20.6	3.2	27.0	23.0	11.0	2	-	2	1	-	38-115CU
CG70M8	H1422A			M8	54.0	20.6	3.2	27.0	23.0	11.0	2	-	2	1	-	
CG70M10	H1422			M10	54.0	20.6	3.2	27.0	23.0	11.0	2	-	2	1	-	
CG70M12	H1423			M12	54.0	20.6	3.2	27.0	23.0	11.0	2	-	2	1	-	
CG70M16	H1423A			M16	54.2	27.5	2.4	27.0	22.0	11.0	2	-	2	1	-	
CG70M11	H1443			M11	54.0	22.2	4.7	27.0	23.0	11.2	2	-	2	1	-	
CG70M20	H1439	Is H1438 Sleeved to suit 19/.083		M20	76.0	28.6	3.5	45.0	25.4	11.0	-	-	-	1	1	38-142CU
CG95M6	H1424B	95	37/1.78	M6	57.2	25.4	4.0	27.0	27.0	13.4	2	-	2	1	1	38-142CU 40-142CU
CG95M8	H1424C			M8	57.2	25.4	4.0	27.0	27.0	13.4	2	-	2	1	1	
CG95M10	H1424			M10	57.2	25.4	4.0	27.0	27.0	13.4	2	-	2	1	1	
CG95M12	H1425			M12	57.2	25.4	4.0	27.0	27.0	13.4	2	-	2	1	1	
CG95M16	H1440			M16	75.5	27.0	3.7	45.0	25.4	13.4	2	-	2	1	1	
CG95M20	H1438			M20	75.5	28.6	3.5	45.0	25.4	13.4	2	-	2	1	1	
CG120M10	H1381	120	37/2.03	M10	68.3	30.0	4.8	31.8	31.0	15.5	-	-	2	2	1	38-165CU 40-165CU
CG120M12	H1382			M12	68.3	30.0	4.8	31.8	31.0	15.5	-	-	2	2	1	
CG120M16	H1383			M16	68.3	30.0	4.8	31.8	31.0	15.5	-	-	2	2	1	
CG120M20	H1382B			M20	68.3	30.0	4.8	31.8	31.0	15.5	-	-	2	2	1	
CG150M10	H1384A*	150	37/2.25	M10	75.0	33.5	5.4	41.3	27.0	16.3	-	-	-	2	1	38-183CU 40-185CU
CG150M12	H1384*			M12	75.0	33.5	5.4	41.3	27.0	16.3	-	-	-	2	1	
CG150M16	H1385*			M16	75.0	33.5	5.4	41.3	27.0	16.3	-	-	-	2	1	
CG150M20	H1386*			M20	75.0	33.5	5.4	41.3	27.0	16.3	-	-	-	2	1	
CG185M10	H1387A	185	37/2.52	M10	79.0	36.5	5.2	41.3	31.0	18.4	-	-	-	2	1	38-200CU 40-200CU
CG185M12	H1387			M12	79.0	36.5	5.2	41.3	31.0	18.4	-	-	-	2	1	
CG185M16	H1388			M16	79.0	36.5	5.2	41.3	31.0	18.4	-	-	-	2	1	
CG185M20	H1389			M20	79.0	36.5	5.2	41.3	31.0	18.4	-	-	-	2	1	
CG240MB	H1390*	240	61/2.25	MB	127.0	41.6	7.1	54.0	47.6	21.2	-	-	-	3	1	38-231CU 40-231CU
CG240M10	H1390D*			M10	127.0	41.6	7.1	54.0	47.6	21.2	-	-	-	3	1	
CG240M12	H1390A*			M12	127.0	41.6	7.1	54.0	47.6	21.2	-	-	-	3	1	
CG240M16	H1390B*			M16	127.0	41.6	7.1	54.0	47.6	21.2	-	-	-	3	1	
CG240M20	H1390C*			M20	127.0	41.6	7.1	54.0	47.6	21.2	-	-	-	3	1	
CG300MB	H1391	300	61/2.52	MB	127.0	46.0	7.9	54.0	47.6	23.8	-	-	-	3	1	38-260CU 40-260CU
CG300M16	H1391A			M16	127.0	46.0	7.9	54.0	47.6	23.8	-	-	-	3	1	
CG300M20	H1391B			M20	127.0	46.0	7.9	54.0	47.6	23.8	-	-	-	3	1	
CG400MB	H1448	400	61/2.85	MB	123.0	49.6	7.9	54.0	41.3	26.9	-	-	-	-	1	50-281CU 40-281CU 66-281CU
CG400M16	H1448A			M16	123.0	49.6	7.9	54.0	41.3	26.9	-	-	-	-	1	
CG400M20	H1448B			M20	123.0	49.6	7.9	54.0	41.3	26.9	-	-	-	-	1	
CG500MB	H1449	500	61/3.20	MB	142.5	54.8	8.2	54.0	55.5	30.0	-	-	-	-	2	50-310CU 40-310CU 66-310CU
CG500M16	H1449A			M16	142.5	54.8	8.2	54.0	55.5	30.0	-	-	-	-	2	
CG500M20	H1449B			M20	142.5	54.8	8.2	54.0	55.5	30.0	-	-	-	-	2	
CG630MB	H1394*	630	127/2.52	MB	146.0	63.5	11.5	54.0	58.0	33.5	-	-	-	-	2	50-70CU 40-370CU
CG800MB	H1370	800	127/2.85	MB	275.0	75.0	14.0	127.0	105.0	39.3	-	-	-	-	3	40-432CU
CG1000MB	H1371	1000	127/3.20	MB	295.0	85.0	16.0	125.0	110.0	44.0	-	-	-	-	3	40-480CU

All sizes of crimp lugs are compatible with imperial size cables except those marked*

1



NARROW PALM

- Specially made for terminating large cables to circuit breakers
- Unique bell mouth for easy insertion of fine stranded conductors
- Made for 99.9%+ high conductivity copper

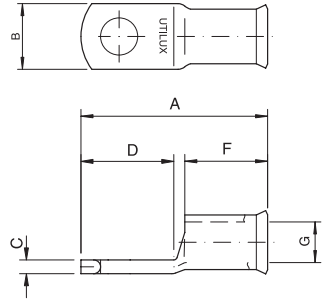

CAT NO.	NOMINAL CONDUCTOR mm ²	BOLT SIZE	DIMENSIONS mm						NO. OF CRIMPS (Tool NO.)					CRIMPING DIE
			A	B	C	D	F	G	20	21	22	38A	40B	
CGNP35M6	35	M6	44	15	2.7	15	21	8.4	2	2	2	1	-	38-92CU
CGNP50M6	50	M6	52	15	3.0	15	22	9.5	2	2	2	1	-	38-104CU
CGNP50M10	50	M10	52	19	3.0	21	22	9.5	2	2	2	1	-	38-104CU
CGNP70M6	70	M6	54	17	3.2	15	24	11.0	2	-	2	1	-	38-115CU
CGNP70M10	70	M10	54	19	3.2	21	24	11.0	2	-	2	1	-	38-115CU
CGNP95M8	95	M8	57	19	4	17	27	13.4	2	-	2	1	-	38-142CU
CGNP95M10	95	M10	57	19	4	21	27	13.4	2	-	2	1	-	38-142CU
CGNP120M8	120	M8	68	19	4.8	23	30	15.5	-	-	2	2	1	38-165CU
CGNP120M10	120	M10	68	19	4.8	23	30	15.5	-	-	2	2	1	38-165CU
CGNP150M8	150	M8	75	19	5.4	27	30	16.3	-	-	-	2	1	38-183CU
CGNP150M10	150	M10	75	19	5.4	27	30	16.3	-	-	-	2	1	38-183CU
CGNP185M10	185	M10	79	31	5.2	32	32	18.4	-	-	-	2	1	38-200CU
CGNP240M10	240	M10	127	31	7.1	32	38	21.2	-	-	-	3	1	38-231CU
CGNP240M12	240	M12	127	31	7.1	32	38	21.2	-	-	-	3	1	38-231CU
CGNP300M10	300	M10	127	31	7.9	32	42	23.8	-	-	-	3	1	38-260CU
CGNP300M12	300	M12	127	31	7.9	32	42	23.8	-	-	-	3	1	38-260CU



COPPER FLARED LUGS

The range of flared copper lugs has been designed with the barrel entry flared to enable an easy insertion of multi stranded cables (flexible cable). The range of connectors (from 25mm² to 185mm²) will ensure most applications for the common flexible cable sizes are covered. The flared copper lugs are made from seamless copper tube, electro tin plated and have the cable area clearly marked on the palm of the lug. The inspection window on the barrel provides a check that the cable has been fully inserted. The flared lugs can be crimped with the standard range of Utilux tooling and hexagonal dies.

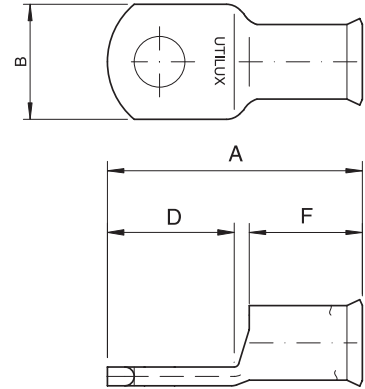

1

CAT NO.	CONDUCTOR SIZE (mm ²)	STRANDING METRIC	BOLT SIZE	DIMENSIONS (mm)				NO. OF CRIMPS (Tool No.)					CRIMPING DIE
				A	B	D	F	20	21	22	38A	40B	
CG25FLM6	25	209/0.40	M6	44	17	19	22	2	2	2	1	-	38-77CU
CG25FLM8		209/0.40	M8	44	17	19	22	2	2	2	1	-	
CG25FLM10		209/0.40	M10	44	17	19	22	2	2	2	1	-	
CG25FLM12		209/0.40	M12	44	17	19	22	2	2	2	1	-	
CG35FLM6	35	285/0.40	M6	44	18	19	22	2	2	2	1	-	38-92CU
CG35FLM8		285/0.40	M8	44	18	19	22	2	2	2	1	-	
CG35FLM10		285/0.40	M10	44	18	19	22	2	2	2	1	-	
CG35FLM12		285/0.40	M12	44	18	19	22	2	2	2	1	-	
CG50FLM8	50	380/0.40	M8	52	21	27	22	2	2	2	1	-	38-104CU
CG50FLM10		380/0.40	M10	52	21	27	22	2	2	2	1	-	
CG50FLM12		380/0.40	M12	52	21	27	22	2	2	2	1	-	
CG70FLM6	70	203/0.67	M6	54	21	27	23	2	-	2	1	-	38-115CU
CG70FLM8		203/0.67	M8	54	21	27	23	2	-	2	1	-	
CG70FLM10		203/0.67	M10	54	21	27	23	2	-	2	1	-	
CG70FLM12		203/0.67	M12	54	21	27	23	2	-	2	1	-	
CG95FLM6	95	259/0.67	M6	57	25	27	27	2	-	2	1	-	38-142CU
CG95FLM8		259/0.67	M8	57	25	27	27	2	-	2	1	-	
CG95FLM10		259/0.67	M10	57	25	27	27	2	-	2	1	-	
CG95FLM12		259/0.67	M12	57	25	27	27	2	-	2	1	-	
CG120FLM10	120	336/0.67	M10	68	30	32	31	-	-	2	2	1	38-165CU
CG120FLM12		336/0.67	M12	68	30	32	31	-	-	2	2	1	
CG120FLM16		336/0.67	M16	68	30	32	31	-	-	2	2	1	
CG150FLM12	150	427/0.67	M12	75	34	32	27	-	-	-	2	1	38-183CU
CG150FLM16		427/0.67	M16	75	34	32	27	-	-	-	2	1	
CG185FLM12	185	518/0.67	M12	79	34	32	31	-	-	-	2	1	38-200CU
CG185FLM16		518/0.67	M16	79	34	32	31	-	-	-	2	1	

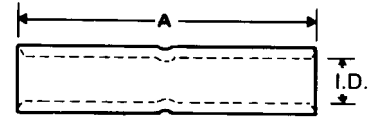

COPPER CRIMP LINKS

- Solid drawn copper tube
- Centre dimples • Ends reamed



DESCRIPT.	CAT NO.	CONDUCTOR AREA mm ²	STRANDING METRIC	DIMENSIONS mm		NO. OF CRIMPS (TOOL NO.)							CRIMPING DIE		
				A	I.D.	00	18	20	21	22	38A	40B			
CK0.5	H1451	0.5	1/0.80	22	2.1	2	-	-	-	-	-	-	-	-	-
CK02.5	H1467	2.5	7/0.67	22	2.5	2	-	-	-	-	-	-	-	-	-
CK4	H1452	4	7/0.85	22	3.3	2	1	-	-	-	-	-	-	-	-
CK6	H1453	6	7/1.04	22	3.7	2	1	-	2	2	1	-	-	38-44CU	-
CK10	H1454	10	7/1.35	22	4.7	2	1	-	2	2	1	-	-	38-57CU	-
CK16	H1455	16	7/1.70	44	5.5	-	3	2	2	2	1	-	-	38-63CU	-
CK20	H1456	20	19/0.044	44	6.3	-	-	2	2	2	1	-	-	38-70CU	-
CK25	H1458	25	19/1.35	48	7.1	-	-	2	2	2	1	-	-	38-77CU	-
CK35	H1488	35	19/1.53	48	8.4	-	-	2	2	2	1	-	-	38-92CU	-
CK50	H1460	50	19/1.78	48	9.5	-	-	2	2	2	1	-	-	38-104CU	-
CK70	H1461	70	19/2.14	51	11.0	-	-	2	-	2	1	-	-	38-115CU	-
CK95	H1462	95	37/1.78	54	13.4	-	-	2	-	2	1	1	-	38-142CU	-
CK120	H1492	120	37/2.03	65	15.5	-	-	-	-	2	2	1	-	38-165CU	-
CK150	H1493*	150	37/2.25	65	16.3	-	-	-	-	-	2	1	-	38-183CU	-
CK185	H1494	185	37/2.52	65	18.4	-	-	-	-	-	2	1	-	38-200CU	-
CK240	H1495	240	61/2.25	89	21.2	-	-	-	-	-	3	1	-	38-231CU	-
CK300	H1496	300	61.2.52	89	23.8	-	-	-	-	-	3	1	-	38-260CU	-
CK400	H1470	400	61/2.85	89	26.8	-	-	-	-	-	-	1	-	40-281CU	-
CK500	H1471	500	61/3.20	114	30.0	-	-	-	-	-	-	2	-	40-310CU	-
CK630	H1499*	630	127/2.52	114	33.5	-	-	-	-	-	-	2	-	40-370CU	-
CK800	H1474	800	127/2.85	230	39.3	-	-	-	-	-	-	3	-	40-432CU	-
CK1000	H1475	1000	127/3.20	230	43.8	-	-	-	-	-	-	3	-	40-480CU	-

All sizes of crimp links are compatible with imperial size cables except those marked*





COPPER CRIMP LINKS - WITH SOLID BARRIER

- For use with oil filled cables
- Solid drawn copper rod
- Electro tinned
- Solid centre barriers
- Ends reamed

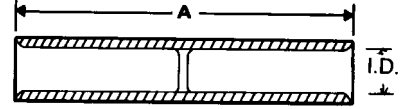

DESCRPT.	CAT NO.	CONDUCTOR AREA mm ²	STRANDING METRIC	DIMENSIONS		NO. OF CRIMPS (Tool No.)					CRIMPING DIE
				A	I.D.	20	21	22	38A	40B	
CKB10	H1782	10	7/1.35	48	4.7	-	2	2	1	-	38-57CU
CKB16	H1781	16	7/1.70	44	5.5	2	2	2	1	-	38-63CU
CKB20	H1786	20	7/2.14	44	6.7	2	2	2	1	-	38-74CU
CKB25	H1779	25	19/1.35	48	7.1	2	2	2	1	-	38-77CU
CKB35	H1791	35	19/1.53	48	8.4	2	2	2	1	-	38-92CU
CKB50	H1770	50	19/1.78	54	9.5	2	2	2	1	-	38-104CU
CKB70	H1771	70	19/2.14	51	11.0	2	-	2	1	-	38-115CU
CKB95	H1772	95	37/1.78	54	13.4	2	-	2	1	1	38-142CU
CKB120	H1792	120	37/2.03	65	15.5	-	-	2	2	1	38-165CU
CKB150	H1793	150	37/2.25	65	16.3	-	-	-	2	1	38-183CU
CKB185	H1794	185	37/2.52	65	18.4	-	-	-	2	1	38-200CU
CKB240	H1795	240	61/2.25	76	21.2	-	-	-	3	1	38-231CU
CKB300	H1796	300	61/2.52	76	23.8	-	-	-	3	1	38-260CU
CKB400	H1797	400	61/2.85	89	26.8	-	-	-	-	1	40-281CU
CKB500	H1798	500	61/3.20	145	30.0	-	-	-	-	2	40-310CU
CKB630	H1799	630	127/2.52	145	33.5	-	-	-	-	2	40-370CU

1

CRIMP CABLE CONNECTOR

- Seamless drawn Copper tube
- Electro tinned

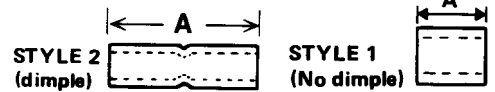

CAT NO.	SIZE	DIMENSIONS mm A	STYLE	TOOL NO.
H2038	1	7.9	1	00, 16B, 76B
H2033	1	15.1	2	00, 16B, 76B
H2039	2	7.9	1	00, 16B, 76B, 18A
H2034	2	15.1	2	00, 16B, 76B, 18A
H2035	3	14.3	2	00, 16B, 76B, 18A
H2042	2 x 24/0.20	6.4	1	00, 16B, 76B
H2022	2 x 50/0.25	8.5	1	00, 16B, 18A
H2027	3 x 32/0.20	9.5	1	00, 16B, 18, 76B
H2043	3 x 32/0.20	7.9	1	00, 16B, 18, 76B
H2029	5 x 32/0.20	9.5	1	00, 16B, 18A
H2041	2 x 50/0.25	11.1	1	20, 38A, 21, 22



REDUCING LINKS

- Solid drawn copper rod
- Electro tin plated • Stock sizes shown
- Custom sizes to order
- Crimp with standard Utilux hex dies

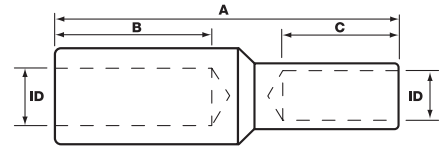

DESCRIPT.	CONDUCTOR AREA mm ²	LARGE END			CRIMPING DIE	SMALL END		CRIMPING DIE
		DIMENSIONS:				DIMENSIONS:		
		A	B	ID		C	ID	
CKR16-6	16-6	55	27	5.5	38-63CU	28	3.7	38-44CU
CKR16-10	16-10	55	27	5.5		28	4.5	38-57CU
CKR25-6	25-6	56	27	7.2	38-77CU	29	3.7	38-44CU
CKR25-10	25-10	56	27	7.2		29	4.5	38-57CU
CKR25-16	25-16	56	28	7.2		29	5.5	38-63CU
CKR35-10	35-10	56	27	8.5	38-92CU	29	4.5	38-57CU
CKR35-16	35-16	56	28	8.5		29	5.5	38-63CU
CKR35-25	35-25	56	28	8.5		28	7.2	38-77CU
CKR50-16	50-16	58	28	9.5	38-104CU	30	5.5	38-63CU
CKR50-25	50-25	58	28	9.5		30	7.2	38-77CU
CKR50-35	50-35	58	29	9.5		30	8.5	38-92CU
CKR70-25	70-25	58	28	11	38-115CU	30	7.2	38-77CU
CKR70-35	70-35	58	29	11		30	8.5	38-92CU
CKR70-50	70-50	58	29	11		30	9.5	38-104CU
CKR95-35	95-35	75	29	13.5	38-142CU	46	8.5	38-92CU
CKR95-50	95-50	75	29	13.5		46	9.5	38-104CU
CKR95-70	95-70	75	30	13.5		46	11	38-115CU
CKR120-50	120-50	75	29	15	38-165CU	46	9.5	38-104CU
CKR120-70	120-70	75	30	15		46	11	38-115CU
CKR120-95	120-95	88	44	15		44	13.5	38-142CU
CKR150-70	150-70	77	30	16.5	38-183CU	48	11	38-115CU
CKR150-95	150-95	90	44	16.5		46	13.5	38-142CU
CKR150-120	150-120	90	44	16.5		46	15	38-165CU
CKR185-95	185-95	90	44	18.5	38-200CU	46	13.5	38-142CU
CKR185-120	185-120	90	44	18.5		46	15	38-165CU
CKR185-150	185-150	90	45	18.5		45	16.5	38-183CU
CKR240-120	240-120	98	44	21.5	38-231CU 40-231CU	54	15	38-165CU
CKR240-150	240-150	98	45	21.5		53	16.5	38-183CU
CKR240-185	240-185	98	45	21.5		53	18.5	38-200CU
CKR300-150	300-150	98	45	24	38-260CU 40-260CU	53	16.5	38-183CU
CKR300-185	300-185	98	45	24		53	18.5	38-200CU
CKR300-240	300-240	101	50	24		51	21.5	38-231CU

Any size can be made for items not shown above – complete Utilux Express form on page 99.



COPPER STALK LUG - TYPE 1

- Electro tinned finish
- Alternative sizes made to order

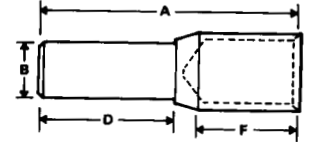

DESCRIPT.	CAT NO.	CONDUCTOR AREA mm ²	STRANDING METRIC	DIMENSIONS (mm)				CRIMPING DIE
				A	B	D	F	
CS1-35/8	H2309	35	19/1.53	70	8	34	25	38-92CU
CS1-50/8	H2313	50	19/1.78	70	8	34	25	38-104CU
CS1-70/10	H2331	70	19/2.14	70	10	34	25	38-115CU
CS1-95/10	H2334	95	37/1.78	70	10	34	25	38-142CU
CS1-120/16	H2314	120	37/2.03	73	16	38	25	38-165CU
CS1-150/16	H2318	150	37/2.25	73	16	38	25	38-183CU
CS1-185/12	H2319	185	37/2.52	73	12	38	25	38/40-200CU
CS1-185/16	H2321	185	37/2.52	73	16	38	25	38/40-200CU

Note: Conductor areas indicated for STYLE 1 are combined areas of wire to be spliced



COPPER STALK LUG - TYPE 2

- Electro tinned finish
- Alternative sizes made to order

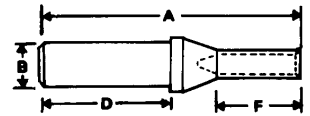

DESCRIPT.	CAT NO.	CONDUCTOR AREA mm ²	STRANDING METRIC	DIMENSIONS mm				CRIMPING DIE
				A	B	D	F	
CS2-16/8	H2341	16	7/1.70	52	8	22	22	38-63CU
CS2-16/10	H2342		7/1.70	67	10	34	22	
CS2-25/10	H2345	25	19/1.35	67	10	34	22	38-77CU
CS2-25/16	H2346		19/1.35	70	16	38	22	
CS2-35/10	H2325		19/1.53	70	10	34	22	
CS2-35/12	H2326	35	19/1.53	70	12	34	22	38-92CU
CS2-35/16	H2327		19/1.53	70	16	34	22	
CS2-50/10	H2350	50	19/1.78	70	10	34	22	38-104CU
CS2-50/16	H2351		19/1.78	73	16	38	22	
CS2-70/16	H2328	70	19/2.14	73	16	38	22	38-115CU
CS2-95/16	H2354	95	37/1.78	70	16	34	22	38-142CU

1



CABLE LUG SOLDER TYPE

- Solid drawn copper tube • Electro tinned • Alternative sizes made to order
- Not recommended for crimping • Bright acid tin finish for easy solderability

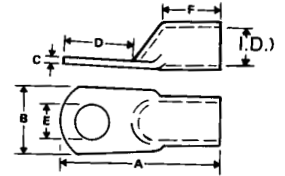

DESCRPT.	CAT NO.	MAX AREA mm ²	NOMINAL AMPS FOR CU CABLE	STUD SIZE E	DIMENSIONS mm					I.D.
					A	B	C	D	F	
SG10	H201	10	75	M5	28.6	8.9	1.8	8.9	9.5	4.5
SG16	H202	16	99	M6	38.6	11.9	1.6	16.0	17.0	6.1
SG35	H203	25-35	155	M8	38.1	16.0	1.8	16.5	12.7	9.3
SG50	H204	50	250	M10	44.5	18.5	2.4	20.5	15.9	10.3
SG70	H205	70	310	M10	56.0	23.1	3.3	27.5	17.9	12.6
SG95	H206	95-120	375	M12	68.0	28.0	3.3	33.5	20.6	15.8
SG120	H207	150	435	M16	79.5	33.0	3.3	36.0	22.2	19.0
SG150	H208	185	570	M20	85.7	37.6	4.0	36.0	28.6	21.3
SG185	H209	240-300	680	M20	106.5	46.5	5.3	48.0	37.0	26.5



SEALED COPPER CRIMP LUGS

- Long barrel length for effective heat shrink sealing
- Designed for outdoor terminations
- Solder sealed • Impervious to air at 140 kPa min

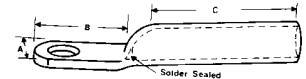

DESCRPT.	CAT NO.	CONDUCTOR AREA mm ²	STRANDING METRIC	STUD SIZE	DIMENSIONS (mm)			CRIMPING DIE
					A	B	C	
SEG25M8	H16011	25	7/2.14-19/1.35	M8	14.7	19	29	38-77CU
SEG25M10	H16012			M10	16.7	19	29	
SEG35M8	H16014	35	19/1.53	M8	18.2	19	35	38-92CU
SEG35M10	H16015			M10	18.2	19	35	
SEG35M12	H16016			M12	20.0	24.5	35	
SEG50M10	H16018	50	19/1.78	M10	19.0	27	38	38-104CU
SEG50M12	H16019			M12	20.6	27	38	
SEG70M10	H16021	70	19/2.14	M10	20.6	27	43	38-115CU
SEG70M12	H16022			M12	20.6	27	43	
SEG95M10	H16023	95	19/2.52	M10	25.4	27	53	38-142CU
SEG95M12	H16024			M12	25.4	27	53	
SEG120M10	H16026	120	37/2.03	M10	30.0	31.8	62	38/40-165CU
SEG120M12	H16027			M12	30.0	31.8	62	
SEG120M16	H16028			M16	30.0	31.8	62	
SEG150M12	H16029	150	37/2.25	M12	33.5	41.3	67	3/40-183CU
SEG150M16	H16030			M16	33.5	41.3	67	
SEG185M12	H16032	185	37/2.52	M12	36.5	41.3	77	38/40-200CU
SEG185M16	H16033			M16	36.5	41.3	77	
SEG240MB	H16035	240	61/2.25	MB	41.6	54	86	38/40-231CU
SEG240M12	H16036			M12	41.6	54	86	
SEG300MB	H16038	300	61/2.52	MB	46.0	54	95	38/40-260CU
SEG300M16	H16039			M16	46.0	54	95	
SEG400MB	H16041	400	61/2.85	MB	49.6	54	98	40/66-281CU
SEG400M16	H16042			M16	49.6	54	98	
SEG500MB	H16044	500	61/3.20	MB	54.8	54	98	40/66-310CU
SEG500M20	H16045			M20	54.8	54	98	
SEG630MB	H16047	630	127/2.52	MB	63.5	54	98	40-370
SEG630M20	H16048			M20	63.5	54	98	



LONG PALM LONG BARREL COPPER CRIMP LUGS

- Long barrel length for effective heat shrink sealing
- No inspection window
- Uses same crimp tools as standard copper lugs

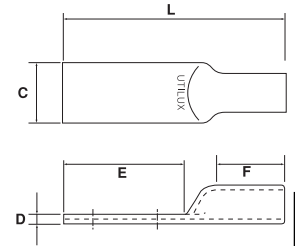

DESCRIPT. P/N	CONDUCTOR AREA mm ²	DIMENSIONS mm					CRIMPING DIE
		C	D	E	F	L	
CG16LPMB	16	13	1.9	70	40	114	38-63CU
CG25LPMB	25	17	1.9	70	40	115	38-77CU
CG35LPMB	35	18	2.7	90	45	140	38-92CU
CG50LPMB	50	21	2.8	100	50	160	38-104CU
CG70LPMB	70	21	3.2	100	50	160	38-115CU
CG95LPMB	95	25	4.0	100	50	160	38-142CU
CG120LPMB	120	30	4.8	100	50	160	38-165CU
CG150LPMB	150	34	5.4	100	50	170	38-183CU
CG185LPMB	185	37	5.4	100	55	170	38-200CU
CG240LPMB	240	42	7.1	110	90	190	38-231CU
CG300LPMB	300	46	7.9	110	90	190	40-260CU
CG400LPMB	400	50	7.9	110	70	210	40-281CU
CG500LPMB	500	55	8.2	110	70	210	40-310CU
CG630LPMB	630	64	11.5	100	70	205	40-370CU

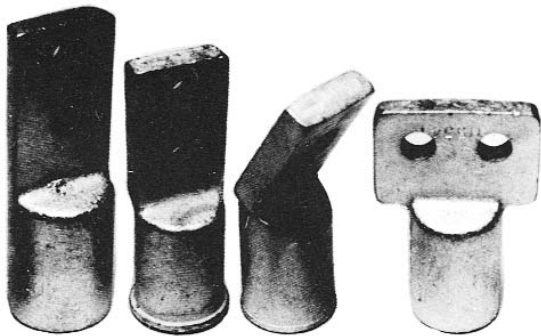

CAST LUGS

- Made to custom requirements
- Made to approved order, quantities only
- Copper alloy, however can be made in other materials
- Type of applications; – diesel electric loco
– transformers – special application



BOLTED CABLE LUG

- Quick and easy termination • Re-usable
- Palms are machined flat and parallel for maximum conductivity
- Copper alloy

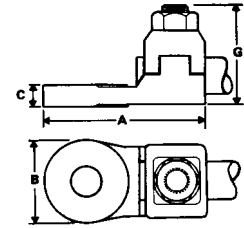

DESCRIPT.	CAT NO.	GENERIC CODE	CONDUCTOR AREA mm ²	NON FLEXIBLE CONDUCTOR	STUD SIZE	DIMENSIONS mm			
						A	B	C	G
BG1	H1801	NO. 1	4-10	7/0.85 7/1.04 7/1.35	M6	34	14	5.5	17
BG2	H1802	NO. 2	16	7/1.70	M8	44	19	5.5	23
BG3 BG3A	H1803 H1803A	NO. 3	25-35	7/2.14 19/1.53	M10 M12	53	25	5.5	27
BG4	H1804	NO. 4	50-70	19/1.78 19/2.14	M12	60	32	6.4	34
BG4C*	H1804C	NO. 4C	50-70	19/1.78 19/2.14	M12	60	32	6.4	34
BG5	H1805	NO. 5	95	37/1.78	M12	65	32	7.9	38
BG6A	H1806A	NO. 6	120	37/2.03	M16	76	38	8.7	45
BG6	H1806	NO. 6	150-185	37/2.25 37/2.52	M16	76	38	8.7	45
BG7	H1807	NO. 7	185-240	61/2.25	M20	86	44	10.3	53
BG8	H1808	NO. 8	300-400	61/2.52 61/2.85	M20	98	51	12.7	63
BG9	H1809	NO. 9	500	61/3.20	M20	100	48	13.5	70

*C = Slot 12mm wide instead of bolt hole



BOLTED TEE CLAMP

- Provide quick and easy tee offs
- Copper alloy
- H1820 and H1821 can be used with slotted palm lugs for easy disconnect facility

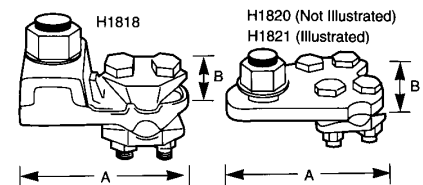

DESCRIPT.	CAT NO.	MAIN CABLE RANGE		TEE CABLE RANGE		DIMENSIONS	
		MIN	MAX	MIN	MAX	A	B
TG185240	H1818	185mm ²	240mm ²	70mm ²	95mm ²	81	33
TG5070	H1820	50mm ²	70mm ²	-	-	79	32
TG7095	H1821	70mm ²	95mm ²	-	-	87	70

'C' CONNECTORS



C-Connectors are manufactured in 'C' shaped copper section for connection of main and tap copper conductors.

- Reliability is ensured by passing tests specified by JIS C 2810
- Suitable for connecting copper conductors in both indoor and outdoor applications such as earth grid connections
- Tin plated • Other sizes available on request (366-700mm²)

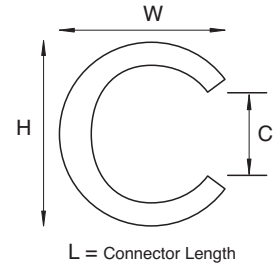
1

DESCRPT.	CAT NO.	CONDUCTOR RANGE mm ²	DIMENSIONS				Die Part No.	INSULATING COVER
			H	W	L	C		
CC10	T-011	7.5 to 11	9	6	12	4	#18C	-
CC16	T-016	11.5 to 16	12	8	13	5	#18C	-
CC20	T-020	14 to 20	13	10	13	5	38-T020	T-020C
CC25	T-026	21 to 26	15	11	16	6	38-T026	T-026C
CC35	T-044	27 to 44	19	14	20	8	38-T044	T-044C
CC50	T-060	45 to 60	21	15	22	10	38-T060	T-060C
CC70	T-076	61 to 76	24	17	22	11	38-T076	T-076C
CC95	T-098	77 to 98	28	19	25	14	38-T098	T-098C
CC120	T-122	99 to 122	30	21	26	13	38-T122	T-122C
CC150	T-154	123 to 154	34	24	28	17	38-T154	T-154C
CC185	T-190	155 to 190	37	25	35	17	38-T190	T-190C
CC240	T-240	191 to 240	40	28	40	19	38-T240	T-240C
CC300	T-288	241 to 288	45	31	45	22	38-T288	T-288C
CC400	T-365	289 to 365	48	34	50	24	38-T365	T-365C

		CONDUCTOR TAP mm ²																	
		2.5	4	6	10	16	20	25	35	50	70	95	120	150	185	240	300	400	
MAIN CONDUCTOR mm ²	6	11	11	16															
	10	16	16	16															
	16	20	20	26	26	44													
	20	26	26	26	44	44	44												
	25	44	44	44	44	44	60	60											
	35	44	44	44	60	60	60	60	76										
	50	60	60	60	60	76	76	76	98	122									
	70	76	76	76	98	98	98	98	122	122	154								
	95	98	122	122	122	122	122	122	154	154	190	190							
	120	154	154	154	154	154	154	154	190	190	190	240	240						
	150	154	154	190	190	190	190	190	190	240	240	288	288	365					
	185	190	190	240	240	240	240	240	240	240	288	288	365	365	450				
	240			288	288	288	288	288	288	365	365	365	365	450	450	560			
	300			365	365	365	365	365	365	365	450	450	450	450	560	560	700		
400								450	450	560	560	560	560	700	700	700			
500								560	560	700	700	700	700	700					
630								700	700	700									

SOLID PALM COPPER LUGS



Utilux have introduced a range of small copper lugs to be used in heavy industry. The range of connectors (6sqmm to 35sqmm) compliments the existing larger size copper cast lugs. The lugs are fabricated from copper rod to maximise the strength. They are made without a seam in the palm, with an increased wall thickness and electro-tinned plated. The solid palm also eliminates the ingress of moisture which makes them suitable for outdoor use. Crimping has been rationalised so that only two (2) sets of dies are required to terminate the full range of lugs.

TYPICAL APPLICATIONS

- Overhead connections for electrical distribution systems
- Railway electrification systems where vibration is a concern
- Other sizes available on request

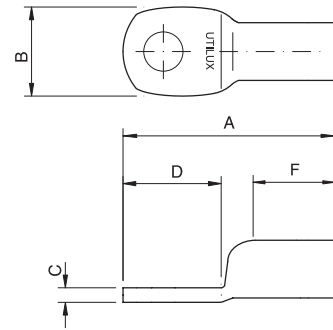

CAT NO.	CONDUCTOR AREA mm ²	BOLT SIZE	DIMENSIONS mm					CRIMPING DIE
			A	B	C	D	F	
CG6SDM6	6	M6	51	16	4.2	21	23	38-77CU
CG6SDM8		M8	51	16	4.2	21	23	
CG6SDM10		M10	51	16	4.2	21	23	
CG10SDM6	10	M6	51	16	4.2	21	23	
CG10SDM8		M8	51	16	4.2	21	23	
CG10SDM10		M10	51	16	4.2	21	23	
CG16SDM8	16	M8	70	21	6.0	27	30	38-104CU
CG16SDM10		M10	70	21	6.0	27	30	
CG16SDM12		M12	70	21	6.0	27	30	
CG25SDM10	25	M10	70	21	6.0	27	30	
CG25SDM12		M12	70	21	6.0	27	30	
CG35SDM10	35	M10	70	21	6.0	27	30	
CG35SDM12		M12	70	21	6.0	27	30	